

HathorSIXA Autofocus

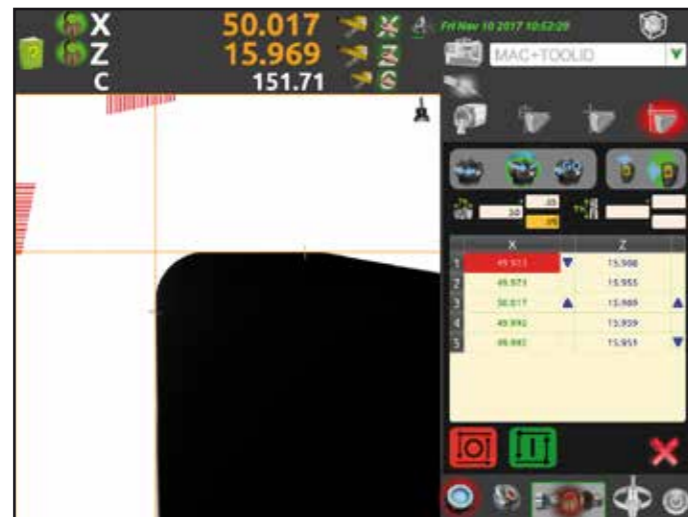

Autofocus function: all new operating mode and capability that allows the machine to measure automatically the tools, without operator presence.

Possibility to acquire X and Z values with automatic recognition of the cutting edge.
 Possibility to set the measuring priority for X or Z axis.
 Absolute maximum measurement automatic searching with complete revolution of the spindle.



Software displays the measuring progression during the automatic acquisition cycle of the cutting edge by circular percentage loader.



TECHNICAL FEATURES

- Measuring range: diameter max 400 mm (radius 200 mm); height max 600 mm
- Machine structure in stainless steel offering high mechanical and long life, floor mounted with self-levelling supports in non-deformable steel
- Base and column made of ground granite: linearity max error 2 µm/Mt certification with Taylor Hobson res.1 µm/Mt electronic millesimal level
- ISO/BT/HSK/VDI etc. Interchangeable rotating spindle-holder (to be selected) max run-out error < 2 µm
- Spindle index in four angular positions: 0°-90°-180°-270°
- C Axis display: spindle holder angular position with 0.01° resolution
- Motor providing automatic rotation of the spindle with pneumatic engagement or the motion transmission for zero backlash (patented system)
- Spindle-holder Identification System (SP-ID) for additional spindle-holder, mounted on the interchangeable spindle
- Double vault arc prismatic slideways: n°2 X axis slideways, n°1 Z axis slideway
- Double re-circulating ball bearing slides (three in total), lubricated for life (preloading slides/slideways: P/H class)
- Universal electro-mechanical tool clamping (ISO/BT only)
- Pneumatic-mechanic braking of the spindle-holder rotation
- Constant load Archimedean spiral spring (as opposed to a mass counter-balance system)
- Vision-system for tool measuring and cutting inspection consisting of:
 - C-MOS sensor - Framed image area 6,4 x 6,4 mm
 - Magnifications about 30X
 - Bi-telecentric lens
 - Red light episcopic leds illuminator with ring lens, red light diasopic led puntiform illuminator
- Machine operator interface through:
 - TFT 15" colour Touch Screen.
 - Intel I3 Quad Core Processor
 - UBUNTU 14.04 LTS LINUX operating system
 - Data storage on solid state disk SSD
 - X and Z axes lock management for a translation speed lower than 2 mm/sec
 - Three USB ports and one LAN networking port
- Standard software:
 - CNC machine origin and spindle adaptor management.
 - Tool list creation and/or single tool.
 - Automatic change of CNC machine origin allocation.
 - Td SIX (Tool Data SIX) to manage:
 - Tools set and Post Processor universal generator;
 - Magnetic chip code-holders (Balluff for example, hardware not included);
 - Printable tool set report;
 - Theoretical measurements and tolerances management.
 - Spindle holder auto rotation with automatic tool measurement cycles
 - Peripheral speed of the spindle rotation is calculated and controlled based on the diameter of the current tool being measured
 - TLA technology (Tool Link App) for tool data transmission directly to numerical control memory (DNC)
 - Ready for TID infrastructure for tool identification with Datamatrix code
- ELBO CONTROLLI Linear Transducers in optical glass type SLIDE 371 certified HP laser:
 - Axes resolution: X= 1 µm, Z= 1 µm.
- Anti-dust cover provided for when not in use.
- Overall dimensions: Length = 1240 mm, Height = 1840 mm, Depth = 558 mm
- Net weight: 190 Kg

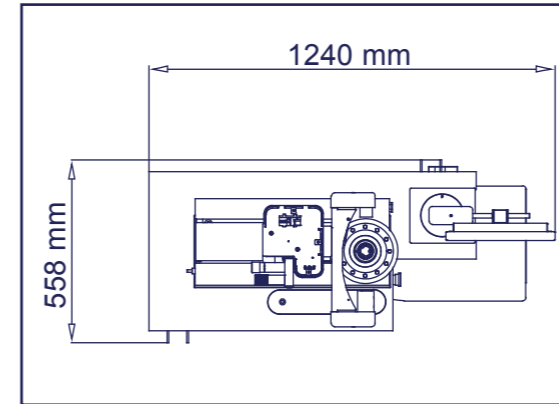
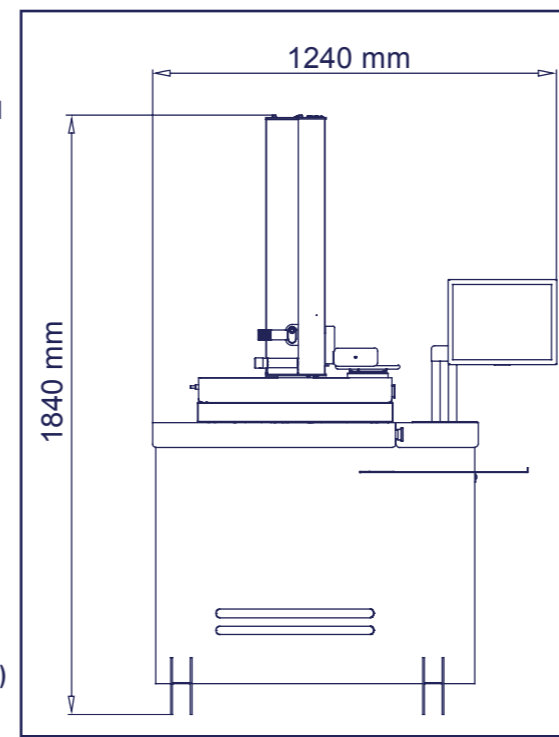

Distributed by

20821 MEDA (MB) - Italy - Via San Giorgio, 21
T. +39 0362 342745 - **F.** +39 0362 342741
www.elbocontrolli.com - info@elbocontrolli.it

SPECIFICATIONS SUBJECT CHANGE WITHOUT PRIOR NOTICE



GLOBAL STRATEGIC PARTNERSHIP





Interchangeable rotating spindle with mechanical rotation brake.
Two preloaded ball cages allow a concentricity accuracy within 2 µm.



Camera system for measuring with punctiform illuminator and inspection with ring illuminator.
C-MOS sensor.
Telecentric optic system with low F/Number.



Micrometric registration of X and Z axes by means of two wheels which are essential for the collimation of the measure with a fixed target function.



Large 15" touch screen for the best visualization of the tools and simple management functions to operate the measuring machine.



Manual axes movement. Axis unclamping by means of a single pneumatic control system.



New electronic control: a powerful fanless PC with Linux operating system for the integrated management of the functions of measurement / inspection tools, machine origins and toolsets. Ease of use thanks to the integrated touch screen.

X and Z axes block management with control maximum speed of translation 2mm/sec.



Inspection function for accurate control of the tool status. Possibility to increase or decrease the brightness for a better visibility. 4 different coloured filters to highlight tool damages.



Base and column made of ground granite. The thermal inertia of this material allows the machine to be placed directly in the workshop. Mechanical elements manufactured from stainless steel.

Td SIX (Tool Data SIX)



Td SIX is a new software function developed by Elbo Controlli, used to acquire tool's measurements, to input them into the tooling tables and create a file including tools offsets.



The data are elaborated and post-processed by the software. There are more than 50 post-processor format for the most common numerical controls available on machine tool market.

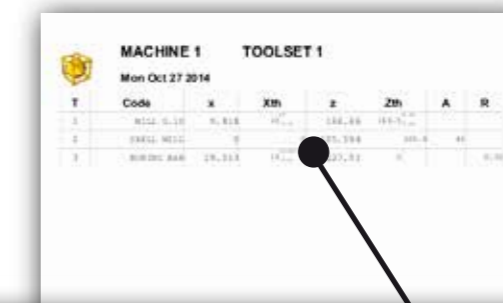

It's possible to generate and / or print a report with the theoretical values, tolerances and measurements of the selected tool table.

MACHINE 1		TOOLSET 1					
Mon Oct 27 2014							
T	Code	x	xTh	z	zTh	A	R
1	MILL D.10	9.918	10 ^{+0,00} _{-0,10}	166.46	166.5 ^{+0,05} _{-0,05}		
2	SHELL MILL	0	0	105.594	105.6	45	
3	BORING BAR	19.013	19 ^{+0,010} _{-0,01}	227.51	0'		0.02