

**NIKKEN**

# PRODUCT OVERVIEW

Solution & Technology Introduction

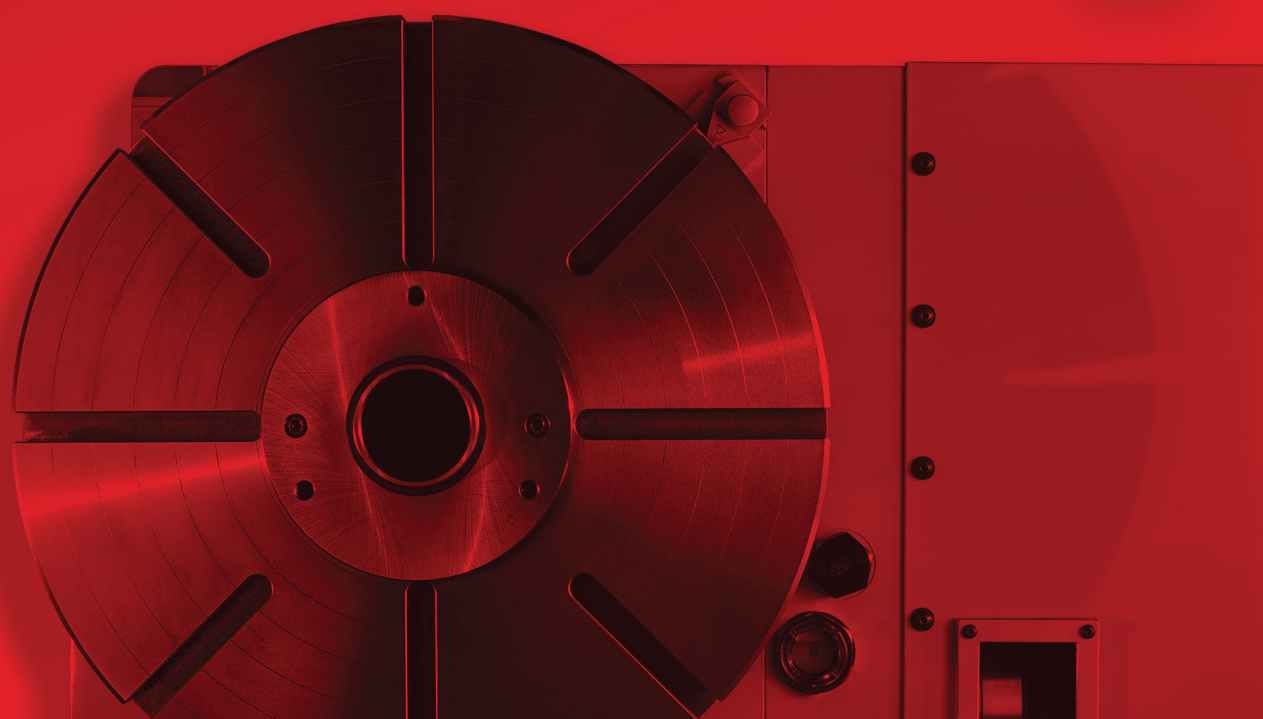

---

# Our Company

Since 1958, NIKKEN solutions have been the power behind some of the world's most demanding products, helping to improve productivity and increase competitiveness in some of the most challenging applications possible.

Our world-class solutions include:

- Performance CNC Rotary Tables
- High accuracy NC Tooling Solutions
- Precision Tool Presetters
- Intuitive Tool Management Solutions
- Spindle Optimisation Solutions

Our range of high precision and durable solutions are favoured amongst high stature manufacturing environments covering aerospace, medical, oil and gas, motorsport, power engineering, and the mould and die sectors.

NIKKEN's extensive product range, combined with technical expertise, training and after-sales service, come together to deliver a superior end-to-end experience that allows our customers the opportunity to successfully compete in the global marketplace.

Visit our industry-leading Research and Development centre, the NIKKEN Innovation Centre Europe (NICE), based at the heart of Advanced Manufacturing in Rotherham, to witness first-hand the power of NIKKEN solutions or utilise our state of the art facilities/services.

## Our Commitment To Sustainability

NIKKEN are committed to sustainable development from the core of our business. We believe that through careful consideration and development, meeting the needs of the present does not have to impact the ability of future generations to meet their own needs. We aim to demonstrate our commitment through our actions, decisions, and products that we introduce to the market.

Ultimately, our goal is to minimise our environmental impact and that of the manufacturing sector by ensuring that every NIKKEN solution and product that we supply offers ultimate longevity, performance, and durability.

**NIKKEN**





**1960**

Official name change to NIKKEN Kosakusho Works Ltd.



**1964**

Opening of the sales office in Tokyo.

**1973**

Opening of the head office in Higashi Ishikiri.

**1981**

Merger with Procomo to form NIKKEN France.

**1989**

Opening of the NIKKEN UK office.

NIKKEN releases its first milling chuck and a universal turning and tilting table. NIKKEN supports the construction of the Japanese highspeed train.

A team of NIKKEN engineers develops the reamer.

Opening of the Higashi Ishikiri reamer factory.

Introduction of the carbide worm system for CNC rotary tables and the AWC system.

Market launch of the NCS tooling system and the ZMAC drilling solution. Opening of NIKKEN China Euro Centres.

**1968**

**1977**

**1984/5**

**1994/6**



## Our history

NIKKEN Kosakusho Europe, based near Sheffield (UK), is a subsidiary of NIKKEN Kosakusho Limited, Japan, with the main responsibility of ensuring the import and distribution of the complete NIKKEN product range in Europe.

With business activities on three continents, offices in over 70 countries and thousands of individual products, NIKKEN is recognised worldwide for innovative solutions of the highest quality. Our employees are the heart of our business. Our goal, no matter where our employees work, is to maintain the unique standards of quality and performance of our products.

NIKKEN Kosakusho constantly strives to improve technology through research and development, innovation and industry expertise to ensure our customers are competitive and successful in their demanding market sectors.

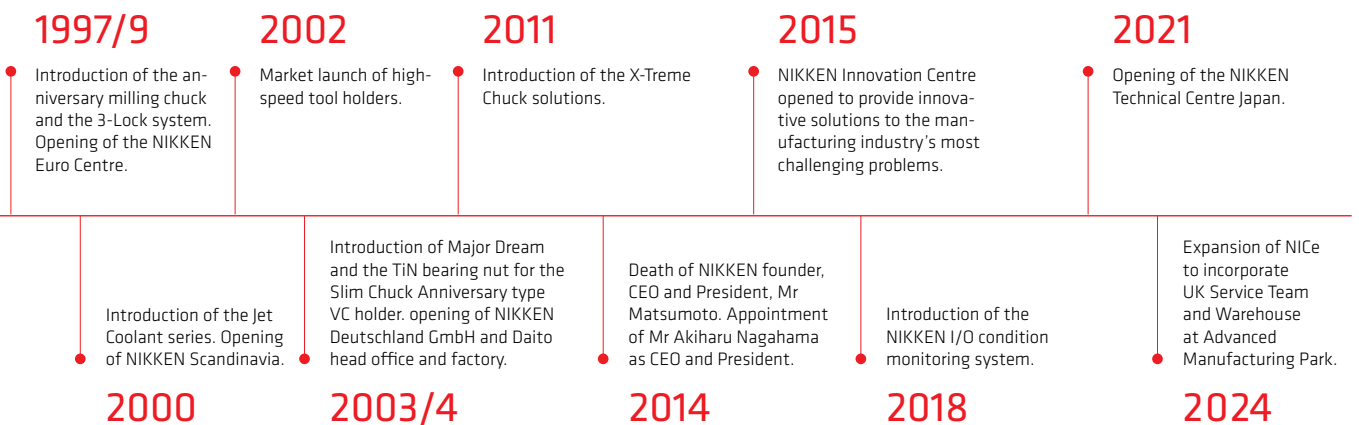

# Tooling Solutions

High rigidity & high accuracy solutions for all machining applications, including a mechanical chuck series, a collet chuck series, a tool holder series with dampening mechanisms, and boring systems.



# Slim Chuck

The Slim Chuck incorporates NIKKEN's exclusive TiN (Titanium Nitrided) Bearing Nut technology. This allows for improved tightening and accuracy, thus delivering better all-round performance.

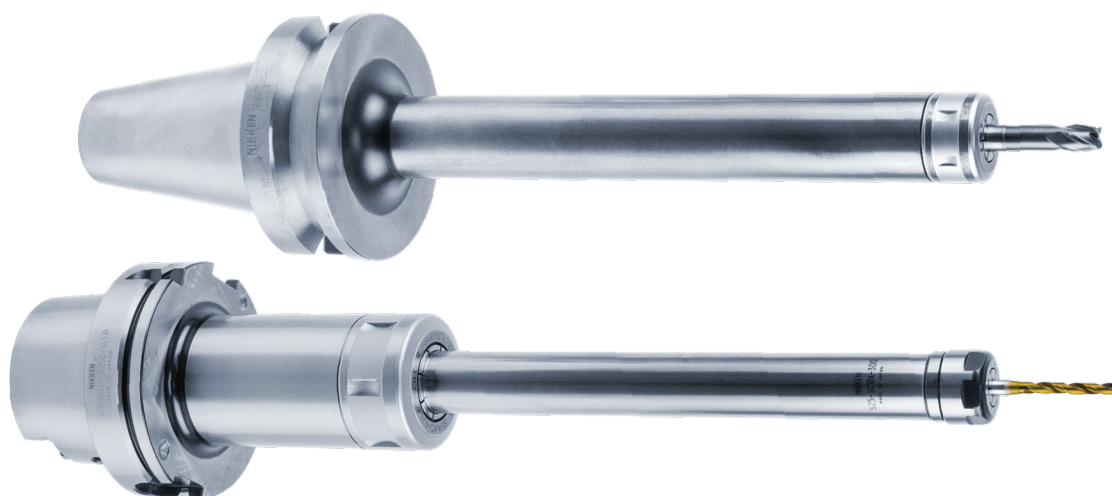

## FEATURES

- Slim and compact body and nut
- 8° Collet with square shoulder location
- Superior gripping torque
- Unique TiN Bearing Nut
- Simple, compact and versatile
- Jet & Centre Coolant options available
- Clamping Range:  $\varnothing 0.7 \sim 25.4\text{mm}$
- Shank: BT/MBT/NBT/HSK/IT/NIT/POLYGON

### TiN Bearing Nut

Simple & compact design for high speed rotation

TiN Bearing Nut

8° taper collet for accuracy & gripping torque

Special coating for high efficiency

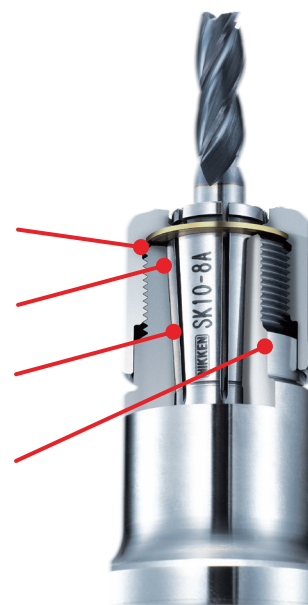

### Run-out Vs. Wear (+30% Life)

To consider the effect that physical run-out contributes to decreases in tool life and increased wear, our ZeroFit Slim Chuck was adopted to actually apply and exaggerate the run-out whilst profile cutting Ti 6Al-4V.

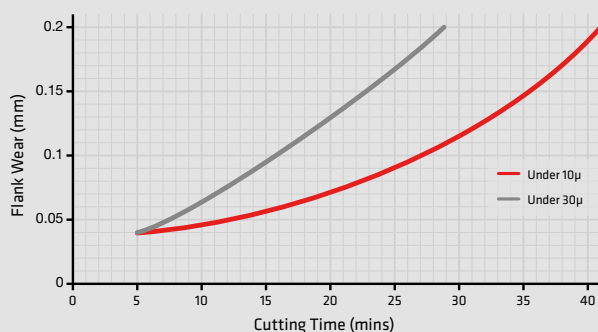

### Collet Concentricity (SK)

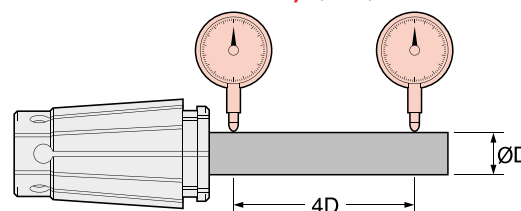

Collet type	Max run-out	
	At nose	At end
Standard	1µ	5µ
P	1µ	3µ
A/AC	1µ	3µ

# Mini-Mini Chuck

Our latest NIKKEN Mini-Mini Advanced Alpha Chuck is simply the most effective product for reduced diameter machining or components and applications where confined access or tight spaces can prove problematic.

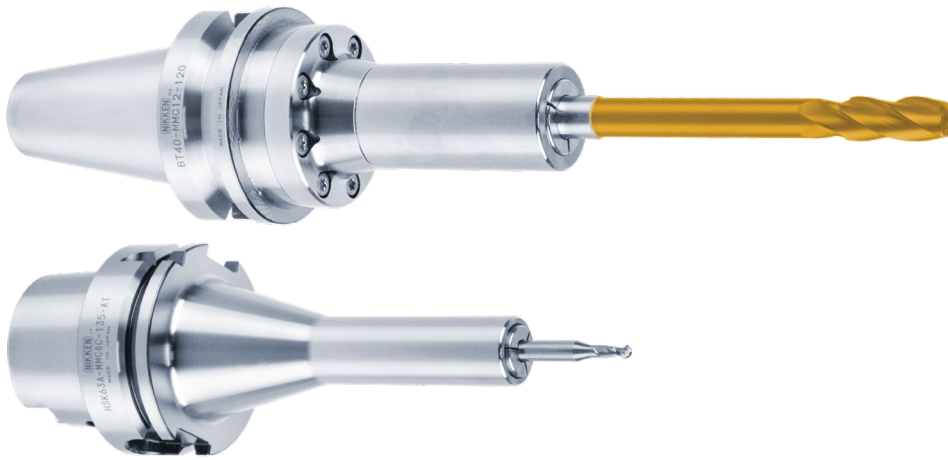

## FEATURES

- Compact construction with no external nut
- Improved internal drawbar & gear mechanism
- Clamp/unclamp with single wrench
- 8° Collet with pilot location
- New HSK “AT” direct draw bar variant
- Jet & Centre Coolant options available
- Clamping Range: Ø1 ~ 12mm
- Shank: BT/MBT/NBT/HSK/IT/NIT/POLYGON

### Latest Generation Alpha Clamping

- Optimised materials and heat treatment process
- Smooth clamping/unclamping from twin TiN bearing arrangement
- Superior support for draw bar gear with one piece construction
- Improved gear design for increased transmission efficiency

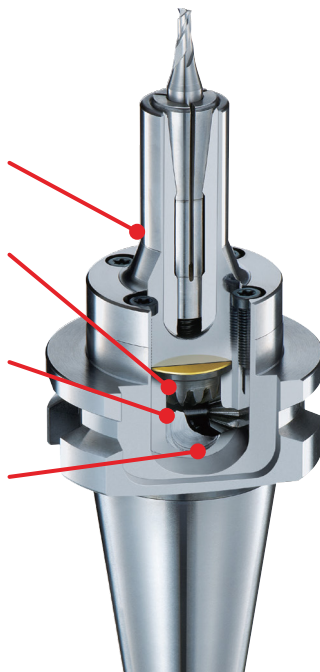

### Collet Concentricity (MPK, PMK, VMK)

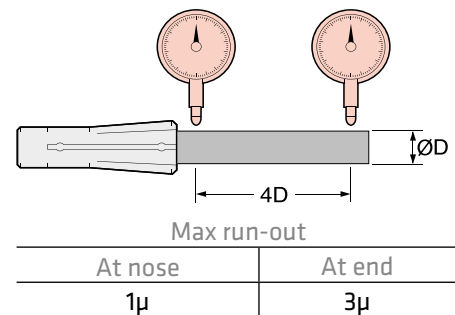

# X-Treme Milling Chuck

Our unique X-Treme Milling Chuck solution provides ultimate performance, control and reliability to meet the requirements associated with challenging components, applications and materials.



## FEATURES

- Designed specifically for demanding applications and materials
- Front nut clamping and accuracy based on Multi-Lock
- Interchangeable face seal and internal stopper
- Positive clamping and retention of tool shank - zero end-mill movement
- Jet & Centre Coolant options available
- Clamping Range:  $\varnothing 12 \sim 42\text{mm}$
- Shank: NBT/HSK/NIT/POLYGON



## Run-out Accuracy

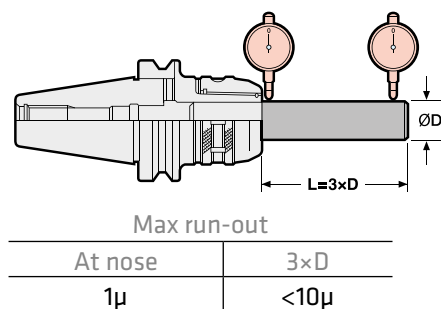

## Total Cutter Security

- Dual mode face sealing options
- World renowned multi-roller construction
- Mechanical face contact
- Unique bolt retention system
- Dual mode location stopper

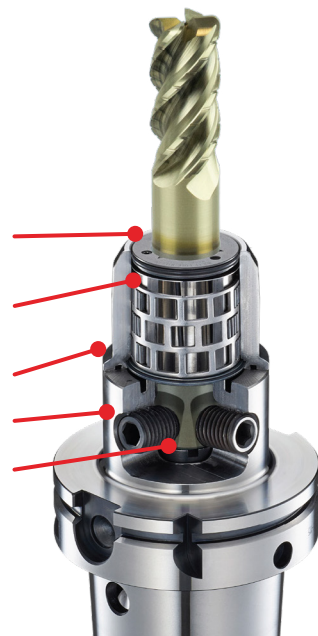

# Multi-Lock Milling Chuck

The Multi-Lock is an efficient and powerful milling solution that also has a versatility to meet the requirements of various applications. The chuck can be utilised as a superior base holder or, with our expansive precision collet range, grip and adapt to numerous other cutting requirements with negligible loss of clamping power.

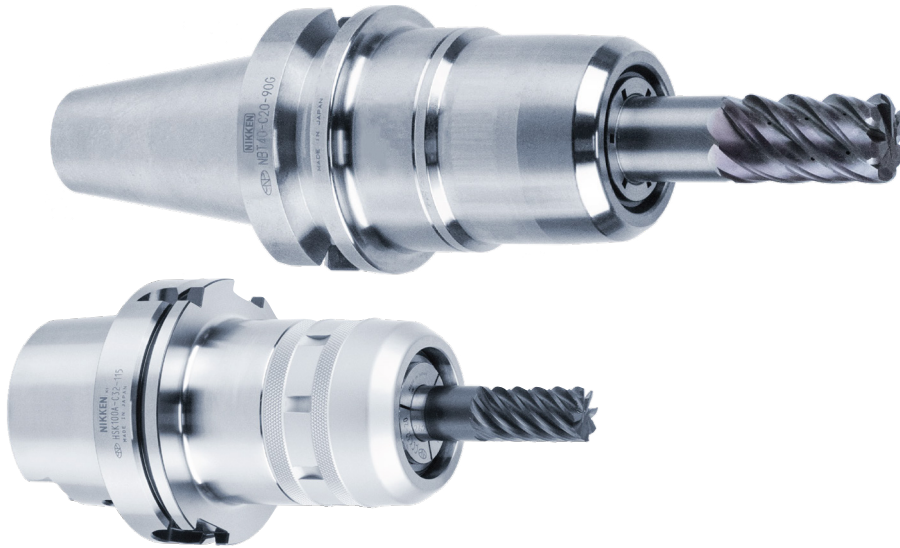

## FEATURES

- High accuracy and rigidity
- Ultimate gripping torque
- Nose and root clamping
- Zero axial movement
- Perfect as a base holder
- Jet & Centre Coolant options available
- Clamping Range: Ø2 ~ 42mm
- Shank: BT/MBT/NBT/HSK/IT/NIT/POLYGON

## Multi Roller System

- Unique slotted bore for improved gripping
- World renowned multi-roller construction
- Mechanical face contact
- Optimum rigidity and performance from NIKKEN's innovative heat treatment process



## Gripping Torque Comparison

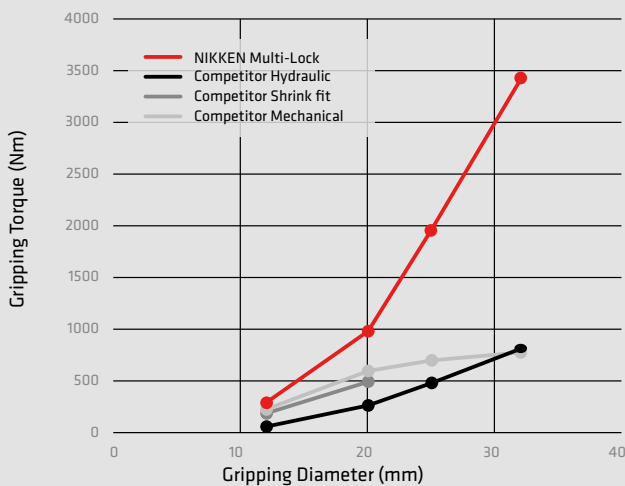

## Run-out Accuracy

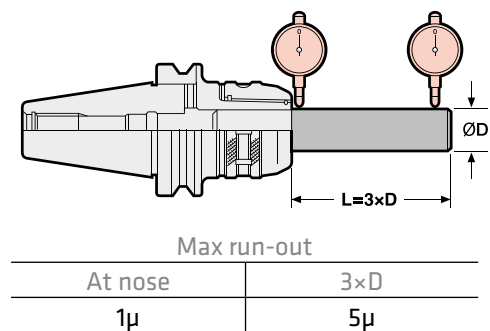

## Zero Fit Holder

When a machine tool has been in operation for 2~3 years, the run-out accuracy of the spindle can decline. The NIKKEN Zero Fit Holder allows correction of any such error back to the “as-new” run-out of 0.001~0.002mm.

Without the Zero Fit Holder, typical run-out, particularly with extended length protrusions, can be in the region of 21 microns - when this is reduced to 3 microns, the tool life can be improved by approximately 5 times.

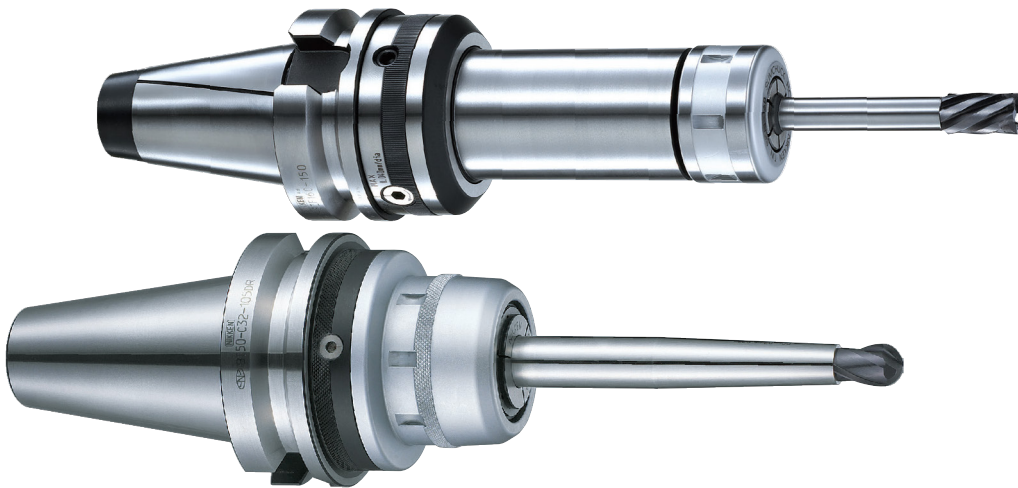

### FEATURES

- 2 variants - Slim Chuck (SZF) and Multi-Lock (CZF)
- Easy to use cam adjustment and locking system
- Available with Single Cam or new Multi Cam design
- Simple optimisation of extended length applications
- Jet & Centre Coolant options available
- Clamping Range CZF:  $\varnothing 2 \sim 42\text{mm}$
- Clamping Range SZF:  $\varnothing 0.7 \sim 25.4\text{mm}$
- Shank: BT/MBT/NBT/HSK/IT/NIT/POLYGON

### Flange Mount Zero Fit

Optimise prismatic work pieces with our Zero Fit solutions for direct mounting on Rotary Table face plates.



### Multi Cam Adjust System

- Twin locking screws
- Balanced adjustment ring
- Fine Adjust Cam (x2)
- Master Cam



# Alberti Angle Heads

T90cn/T90

Alberti products consistently exceed expectations, boasting an average working time that surpasses competitors in the same market segment. They are the ideal solution for machining even the most complex workpieces, eliminating the need for additional setups.

Our angle heads are easy to install and can be customized to meet specific customer requirements. They can be fitted on any machine, either through automatic tool change or manual mounting, to maximize spindle capacity.



## FEATURES

The different models can offer, depending on the line:

- Fixed angle 90°
- Swivelling angles +/- 95°
- High-pressure internal coolant of up to 100 bar
- Smart Change System
- Possibility of extending the body with specially designed modules.

Alberti angle heads are divided into different lines:

- **Control line** - with stop block and pin pivot suitable to be automatically exchanged.
- **Modular line** - with heads suitable to be installed on conventional machine tools.
- **P modular line** - for conventional and large machine tools.
- **Index Line** - to orient and position the output spindle of the head around 360° automatically through the machine spindle.
- **Smart Change Line** - the innovative system for a great saving in set up time and costs.

Our exclusive angle head range, developed and manufactured in conjunction with our partner Alberti SRL, brings the accuracy and performance of NIKKEN's SK (Slim Chuck) 8° spindle taper, TiN Bearing Nut and 8° precision collet to the output spindle of an angle head. With a run-out guarantee of 5µm at 4 × diameter, the solution provides substantially increased capabilities over than of similar ER based solutions.



# Major Dream Holder

NIKKEN's Major Dream System provides the optimum anti-vibration tool holder solution. Using NIKKEN's revolutionary micro-dampening mechanism, it is suitable for both heavy-duty and high-speed machining.

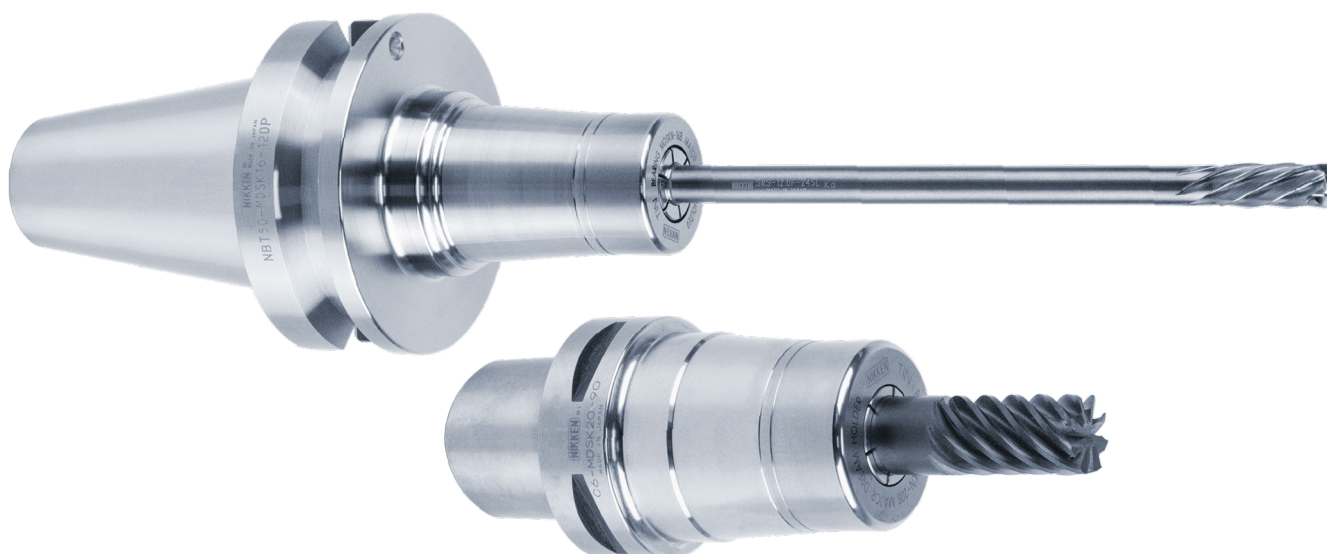

## FEATURES

- Run-out guarantee  $3\mu\text{m}$  at  $4 \times \text{Diameter}$  (with recommended 'A' type collet)
- TiN Bearing Nut
- Unique internal construction provides 'built-in' dampening and anti-vibration
- $8^\circ$  Collet System
- Square Shoulder Pushing
- High-speed options available up to 30,000rpm @ G2.5
- Jet & Centre Coolant options available
- Clamping Range:  $\varnothing 3 \sim 25.4\text{mm}$
- Shank: BT/MBT/NBT/HSK/IT/NIT/POLYGON



## Collet Concentricity (SK)

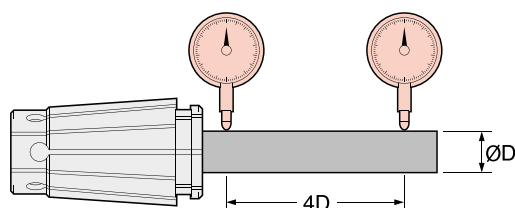

Collet type	Max run-out	
	At nose	At end
A/AC	$1\mu$	$3\mu$

## Internal Dampening Mechanism

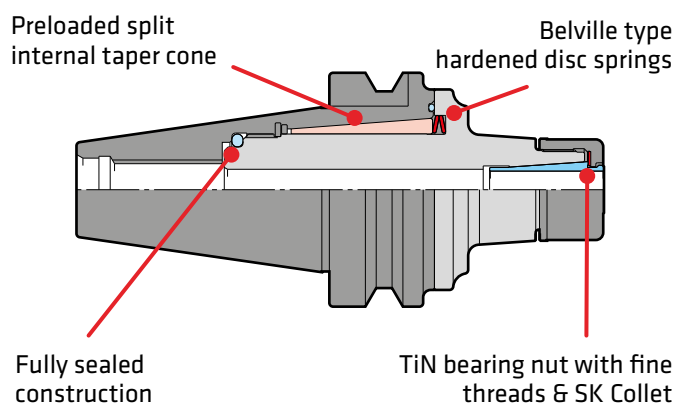

# Anniversary VC Holder

VC is our solution for tougher milling and drilling processes. Incorporating many proven features and construction elements from the Slim Chuck, we have enhanced the whole product with a focus on performance.



## FEATURES

- Strengthened nut and increased body wall thickness
- More suited to the demands of milling processes
- 8° Collet with pilot location
- Superior gripping torque
- Unique TiN bearing nut with finer threads for greater contact
- Jet & Centre Coolant options available
- Clamping Range: Ø3 ~ 12 mm
- Shank: BT/MBT/NBT/HSK/IT/NIT/POLYGON K/IT/NIT/POLYGON



## Collet Concentricity (VCK)

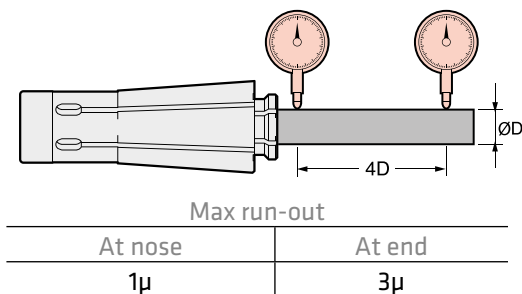

## Increased Milling Capability

- Stronger wall construction with fine threads for improved clamping and rigidity
- TiN Bearing Nut
- 8° taper collet for accuracy & gripping torque
- Pilot diameter for increased collet support during milling processes

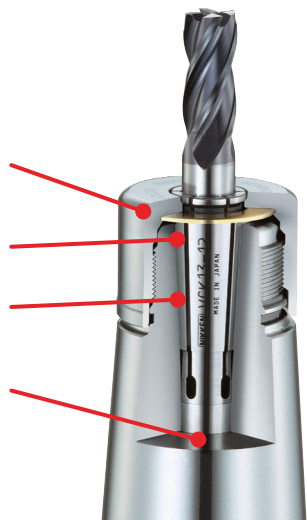

# ZMAC Advanced Boring

Our ZMAC Advanced Boring Heads feature a double-contact shoulder support and provide excellent reliability and performance for deep hole boring and high-speed boring operations.



## FEATURES

- Unique double contact support
- High precision with simple micron adjustment
- Superior stability and rigidity
- Available as modular solution or more rigid “blade type” system for larger diameters
- Light alloy version available for higher speeds
- Modular Range: Ø15.9 ~ 180.5mm
- Large Range: Ø140 ~ 595mm
- Shank: BT/MBT/NBT/HSK/IT/NIT/POLYGON

### Fine Boring Solution

Cartridge fully supported throughout travel

Coolant through capability as standard

Hardened cartridge thread (HRC50-55) with precision grinding to ensure easy micro adjustment



# DJ Boring

Adopting two sizes of head and an ever increasing range of boring bits, the DJ Boring System provides the versatility and range to cater for smaller diameter boring processes. The system allows micron accuracy and caters for any requirement by simply replacing the boring bit itself.

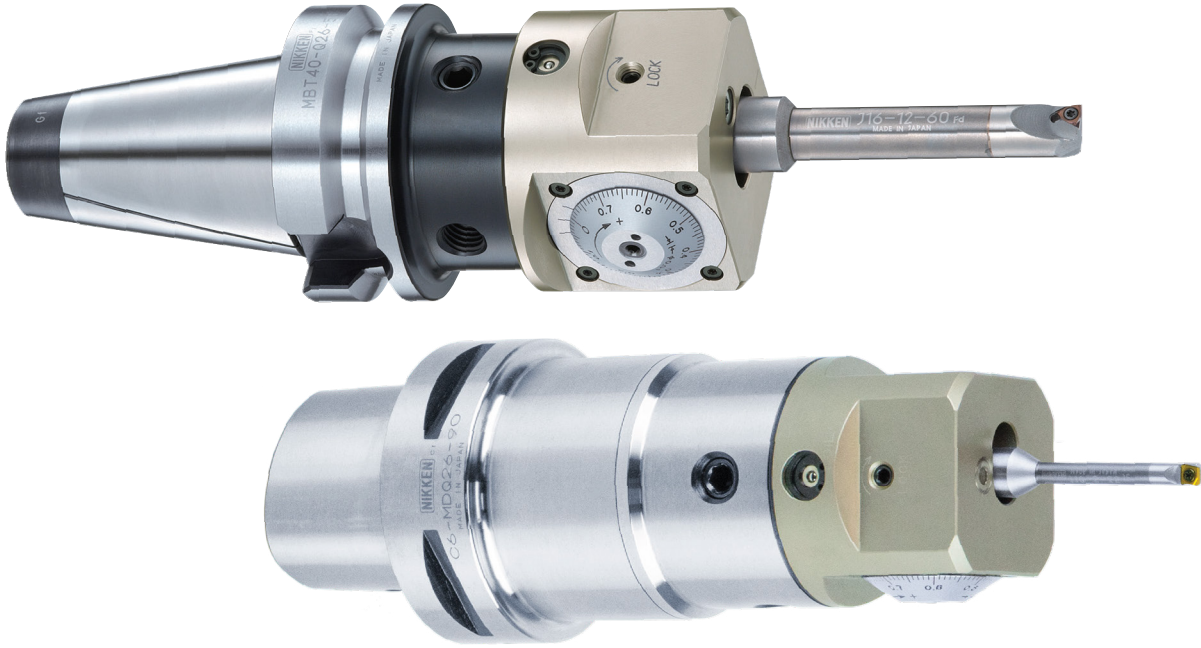

## FEATURES

- Versatile and easy to use
- Carbide boring bits negate vibration
- Straight forward accurate adjustment
- Compatible with alternative boring bits
- New DJ 8 reduction sleeve - 16mm to 10mm
- Boring Range: Ø3 ~ 50mm
- Shank: BT/MBT/NBT/HSK/IT/NIT/POLYGON

### Versatility in Boring

Extensive range covered by a wide variety of boring bits

Easy to set micron accuracy

Graduation main dial is 0.01mm/dia. Vernier reading is 0.005mm

Available for any machine spindle by using a NIKKEN Q26 modular base holder

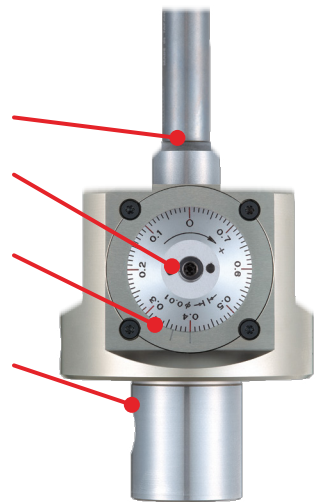

### DJ Boring Bits

A versatile range of boring bits with carbide dampening are available from stock, either individually or included within complete sets.



# RAC Advanced Boring

NIKKEN RAC Boring Heads feature a precision ground serration, giving perfect contact and balance between the holder and head. The RAC system provides the rigidity and stability to cater for larger diameter boring operations, including roughing and semi-finishing.

## FEATURES

- Both cartridges feature precision ground V form slideways to support each other to negate cutting forces
- Suitable for double cutting and stepped cutting (option)
- Cartridges available to suit various insert styles
- Modular Range:  $\varnothing 25 \sim 130\text{mm}$
- Large Range:  $\varnothing 130 \sim 580\text{mm}$
- Shank: BT/MBT/NBT/HSK/IT/NIT/POLYGON

### Performance & Rigidity

Double cutting with twin, self supporting cartridges

Precision ground "V" form slideways (NIKKEN scam)

Numerous cartridge options for different materials and processes

Available for any machine spindle by using a NIKKEN Q26 modular base holder

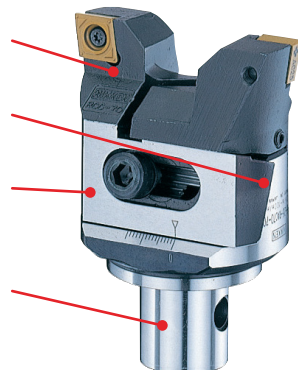

### Balance-Cut RAK/RPC Arbor & Blade

For demands from  $\varnothing 130 \sim 580\text{mm}$ , our Balance-Cut blade system is adopted (now also available in our new lightweight aluminium Alpha configuration). Both solutions incorporate many of the characteristics of the standard modular RAC with the rigidity necessary for larger diameters. Balance-Cut is also available as a ZMAC finishing solution, and both options can be configured for high-pressure coolant.

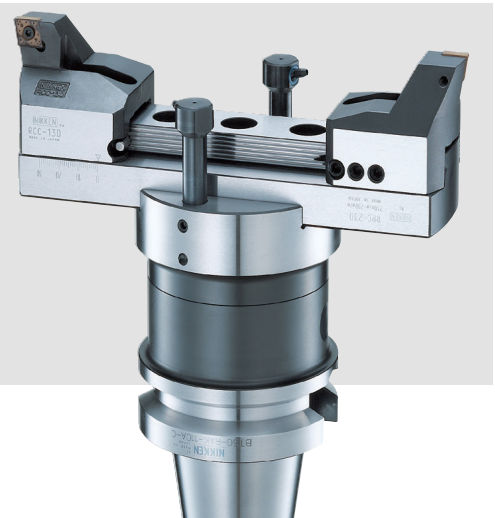

# eMAC-P Digital Boring

The NIKKEN eMAC Digital Boring System is a fine boring head with a digital display indicating the radial slide traverse. The target adjustment can be achieved easily, quickly and precisely. The brand new eMAC-P features improved sealing which provides 'ingress protection' to IP69K instead of original IP67.

## FEATURES

- Single button operation for 'On' & 'Reset', and to change between mm/inch
- Adjust screw
- Digital display resolution  $\varnothing 2\mu\text{m}$
- Available for any machine spindle by using a NIKKEN Q26 modular base holder
- Modular Range:  $\varnothing 6 \sim 200\text{mm}$
- Shank: BT/MBT/NBT/HSK/IT/NIT/POLYGON



### Digital Adjustment

Single button operation for 'On' & 'Reset', and to change between mm/inch

Adjust screw

Digital display resolution  $\varnothing 2\mu\text{m}$

Available for any machine spindle by using a NIKKEN Q26 modular base holder



### EMAC BOXSET

NIKKEN offer a complete EMAC boxed set featuring a free NIKKEN high-precision modular base holder, saving you £1,285 off the list price!

# V-EX Vacuum Extractor

**The cost-effective solution to efficient in-process waste extraction.**

Machining non-metallic materials generates a lot of waste by-product and dust. These potentially abrasive particles accelerate the wear of machine tool components, and create a health risk through dust inhalation.

Extracting these particulates prolongs machine tool life and ensures compliance with health and safety regulations.

Existing extraction solutions, however, can add up to 10% to the cost of a new machining centre, deterring manufacturers from entering the market for machining materials like composites, plastics and foams, which produce a large amount of dust.

To address the problem, NIKKEN has developed an innovative, low-cost vacuum extraction system that can be retrofitted to any machining centre. With no need for a power supply and no moving parts, the V-EX is suitable for both wet and dry cutting conditions. With the ability to handle many different particle types and sizes, including conductive dusts, this makes V-EX a perfect low-cost solution for any non-metallic machining operation.



## FEATURES

- A cost effective, retrofittable solution to dust and particle removal for new and existing machining centres.
- Significantly reduces damage and wear caused by abrasive waste materials.
- Suitable for both wet and dry cutting applications.
- Addresses health risks posed by dust inhalation.
- Promotes a smooth cutting operation by removing waste from the cutting zone.
- Requires only an air supply, and can be coupled to many existing extraction systems.

# NIKKEN EU SHRINK FIT

We are delighted to launch the ultimate Shrink-Fit solution under our new & exclusive brand for Europe, NIKKEN eu. Developed and manufactured using carefully selected materials and processes, our latest tool holding range has been designed to meet the demands of any application requirement in the most competitive markets.

## FEATURES

- Precise tool holder balancing for improved surface finishes.
- Superior tool run-out of less than 0.003mm.
- Greater rigidity with cutting tool shank gripped at 360° for the whole bore length.
- Front bore recess to ease tool loading, reduce shrinking heat and optimise tool holder life.
- All benefits combined provide better distribution of the chip load along the cutting edge and ultimately increased tool life.





## Full Capital Expensing Programme

**Take advantage of the UK Governments Full Capital Expensing Scheme and receive 25p for every £1 invested in machinery.**

With the tax scheme available until March 2026 and on capital purchases such as:

- Tooling Packages
- Rotary Tables with/without Workholding accessories
- Tool Presetters
- Tool Management Software

Take the opportunity to save on your tax bill whilst gaining long term investment benefits, reducing scrap and enhancing productivity.

### Key Facts:

- Full expensing – which offers 100% first-year relief to companies on qualifying new main rate plant and machinery investments from 1 April 2023 until 31 March 2026
- The 50% first-year allowance (FYA) for expenditure by companies on new special rate (including long life) assets until 31 March 2026
- The Annual Investment Allowance (AIA) provides 100% first-year relief for plant and machinery investments up to £1 million, which is available for all businesses, including unincorporated businesses and most partnerships



## 60 Years of Innovation

At the heart of each and every NIKKEN Rotary Table is our patented carbide worm system offering an unrivalled mechanical solution for incredible precision and lifelong durability.

# NIKKEN I/O

NIKKEN IO ensures your Rotary Table performs optimally, producing quality parts repeatably and reliably, as is expected with all NIKKEN products.

With 24/7 monitoring and real-time performance data available at any time of the day, through either an app or desktop device, NIKKEN IO provides manufacturers with valuable data such as uptime, usage, 3 phase current and collision detection.

Live notifications allow manufacturers the opportunity to quickly eliminate unnecessary costs produced from table neglect, collisions, power failures and more.

NIKKEN IO is ideal for manufacturers seeking a sustainable manufacturing process whilst alleviating machine downtime and scrap material.



## HOW I/O WORKS

1. Sensors inside the rotary table collect and process real-time data during usual production processes.
2. Key snapshots of information are uploaded to a centralised database for storage and further analysis.
3. The NIKKEN I/O web-based dashboard then provides rich, customisable data visuals with an at a glance flagging system, so you can ensure that your investments are performing at their optimal capability.
4. Scheduled alerts and updates can deliver up-to-date information directly into your mail inbox, highlighting any important information.

## STANDARD FUNCTIONALITY:

- Backlash classification;
- Tri-axial collision detection;
- Uptime;
- Usage duration;
- 3-phase current monitoring.

# Rotary Table Capabilities

World renowned CNC Rotary Tables with proven performance, reliability and accuracy benefits which others simply cannot emulate.

**PROUD SUPPLIERS TO:**



# Direct Drive

NIKKEN Direct Drive Rotary Tables are simple and accurate. Direct Drive tables feature no mechanical reduction mechanism such as the worm system within a standard rotary table.

Direct Drive Rotary Tables have the motor effectively 'built-in' to the rotary table body directly driving the axes and faceplate.

The tables provide extremely high rotation speeds with high acceleration and deceleration. The only limit is the driving torque of the motor! The application needs to be considered but NIKKEN Direct Drive Rotary Tables are suitable for numerous applications where complicated forms and shapes can be machined effectively and quickly.

## Direct Drive 4<sup>th</sup> Axis Range

Table Diameter - **Ø180 ~ 400mm**  
 Clamping Torque - **150 ~ 1000Nm**  
 Rotation Speed - **125 ~ 200min<sup>-1</sup>**

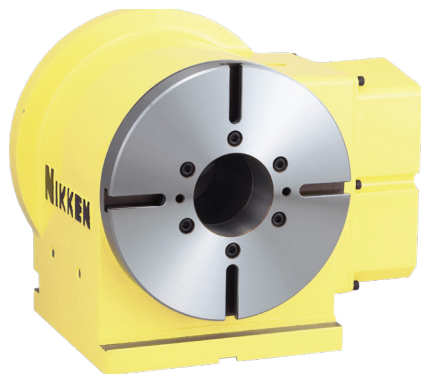

**DD250F-150** Direct Drive 4<sup>th</sup> Axis Table

Diameter of Table	250mm
Clamping System	Pneumatic
Clamping Torque	500Nm
Minimum Increment	0.001°
Indexing Accuracy	±10sec
Max Work Load on the Table	100kg
Max Torque	380Nm

## Direct Drive 5<sup>th</sup> Axis Range

Table Diameter - **Ø90 ~ 200mm**  
 Clamping Torque - **75 ~ 500Nm**  
 Rotation Speed - **150 ~ 200min<sup>-1</sup>**

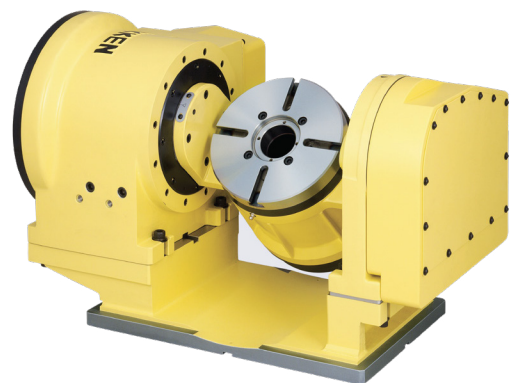

**SAX-DD201BF3** Direct Drive 5<sup>th</sup> Axis Table

Diameter of Table	200mm	
Clamping System	Air	
Clamping Torque	Rotary 150Nm	Tilting 500Nm
Minimum Increment	0.001°	
Indexing Accuracy	Rotary	Tilting
Max Work Load on the Table	0-30° 30Kg	30-90° 30Kg
Driving Torque	Rotary 150Nm	Tilting 500Nm

## High-Speed & Direct Drive!

NIKKEN's Direct Drive Rotary Tables are now also available with high-speed rotation to provide the added benefits of turning capabilities to a conventional VMC.

# Single Axis CNC Tables

NIKKEN's small to medium single axis CNC Rotary Table range is designed to cater for a wide variety of processes, applications and machine tools where positional accuracy, reliable/repeatable performance and stability are key. Usable either as a direct CNC driven full forth axis or with the addition of our Alpha 21 controller (for either positioning or more complete control with Macro B) our solutions can be adapted to virtually any machine or process.

Our large single axis and Big Bore CNC Rotary Table options provide the performance demanded by larger scale processes, applications and machine tools. Here we excel with all the benefits and characteristics of the smaller range but with increased rigidity and considerations applied to the construction. Again usable either as a direct CNC driven full forth axis or with the addition of our Alpha 21 this range extends capabilities and expectations such components and requirements.

## Compact 4<sup>th</sup> Axis Range

Table Diameter -	Ø105 ~ 200mm
Clamping Torque -	205 ~ 900Nm
Rotation Speed -	22.2 ~ 66.6min <sup>-1</sup>

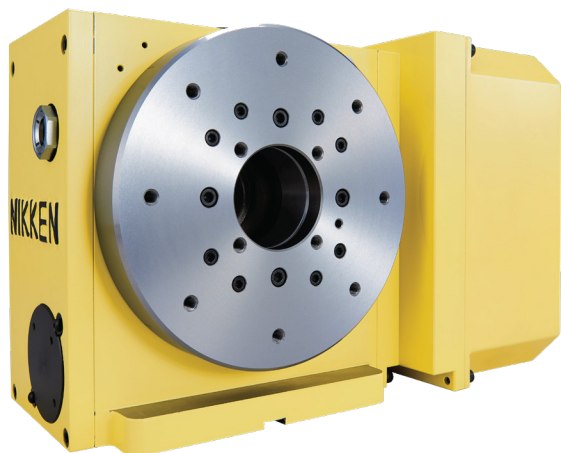

**NCT200** Compact 4<sup>th</sup> Axis Table

Diameter of Table	200mm
Clamping System	Pneumatic
Clamping Torque	900Nm
Minimum Increment	0.001°
Indexing Accuracy	±20sec
Max Work Load on the Table	V=100Kg / H=200Kg
Driving Torque	151Nm

## Mid Range 4<sup>th</sup> Axis Range

Table Diameter -	Ø260 ~ 400mm
Clamping Torque -	588 ~ 1760Nm
Rotation Speed -	16.6 ~ 66.6min <sup>-1</sup>

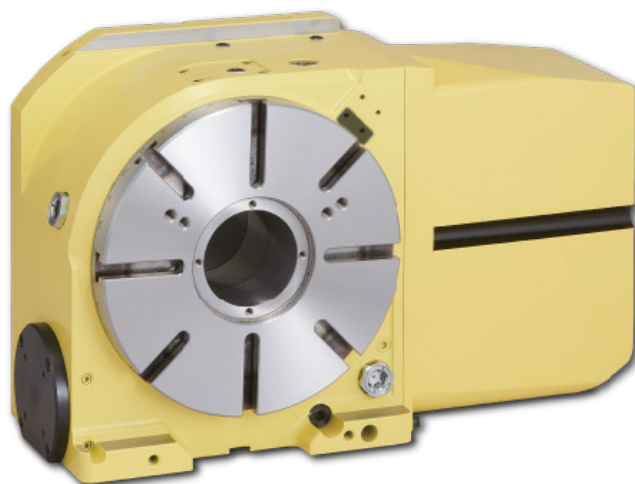

**CNC260P** Mid Range 4<sup>th</sup> Axis Table

Diameter of Table	260mm
Clamping System	Pneumatic
Clamping Torque	1550Nm
Minimum Increment	0.001°
Indexing Accuracy	20sec
Max Work Load on the Table	V=175Kg / H=350Kg
Driving Torque	192Nm

## FEATURES

- Monoblock high performance main spindle
- Ion-nitrided worm wheel HV1100
- Special steel/carbide worm screw system
- Dynamic high-pressure oil film effect (Z series)
- Bespoke work-holding available
- Long life durability and performance from entirely NIKKEN manufactured components

### Big Bore 4<sup>th</sup> Axis Range

Table Diameter -	Ø350 ~ 630mm
Clamping Torque -	3331 ~ 65503Nm
Rotation Speed -	5.5 ~ 33.3min <sup>-1</sup>

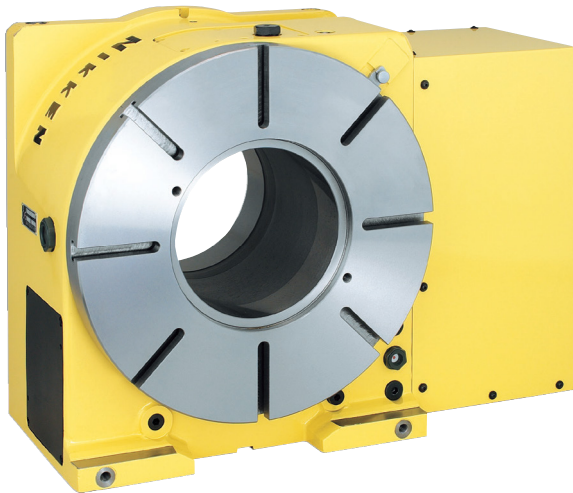

### Large 4<sup>th</sup> Axis Range

Table Diameter -	Ø500 ~ 1600mm
Clamping Moment -	4655 ~ 35000Nm
Rotation Speed -	2.7 ~ 33.3min <sup>-1</sup>

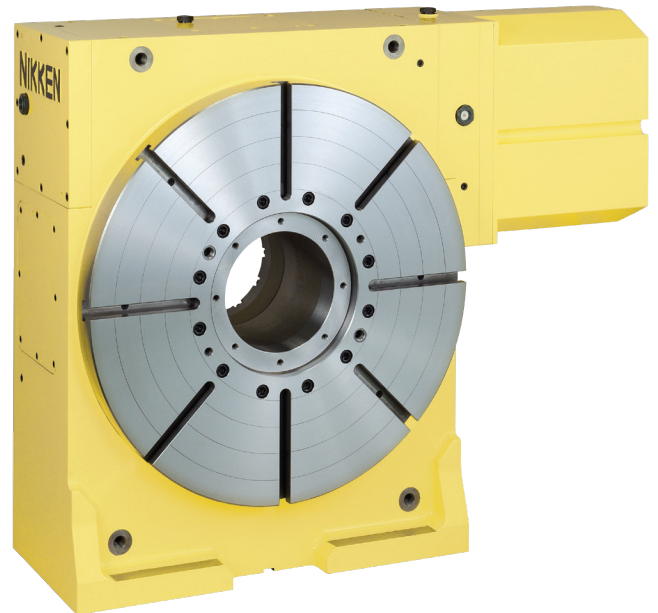

#### CNCB450 Big Bore 4<sup>th</sup> Axis Table

Diameter of Table	450mm
Clamping System	Hyd
Clamping Torque	7401Nm
Minimum Increment	0.001°
Indexing Accuracy	15sec
Max Work Load on the Table	V=350Kg / H=700Kg
Driving Torque	576Nm

#### CNC803 Large 4<sup>th</sup> Axis Table

Diameter of Table	800mm
Clamping System	Hyd
Clamping Torque	27067Nm
Minimum Increment	0.001°
Indexing Accuracy	15sec
Max Work Load on the Table	V=2000Kg / H=4000Kg
Driving Torque	3168Nm

## Twin Axis CNC Tables

NIKKEN's small to medium twin axis CNC Rotary Table range is designed to cater for a wide variety of processes, applications and machine tools where positional accuracy, reliable/repeatable performance and stability are key. Usable either as a direct CNC driven full forth axis or with the addition of one or even two of our Alpha 21 controllers (for either positioning or more complete control with Macro B) our solutions can be adapted to virtually any machine or process.

Our large twin axis CNC Rotary Table options provide the performance demanded by larger scale processes, applications and machine tools. Here we excel, with all the benefits and characteristics of the smaller range, but with increased rigidity and considerations applied to the construction. Again usable either as a direct CNC driven full fourth axis or with the addition of our Alpha 21 this range extends capabilities and expectations.

### Compact 5<sup>th</sup> Axis Range

Table Diameter -	Ø90 ~ 200mm
Clamping Torque -	205 ~ 612Nm
Rotation Speed -	11.1 ~ 44.4min <sup>-1</sup>



### Mid Range 5<sup>th</sup> Axis Range

Table Diameter -	Ø230 ~ 350mm
Clamping Torque -	490 ~ 1568Nm
Rotation Speed -	5.5 ~ 33.3min <sup>-1</sup>

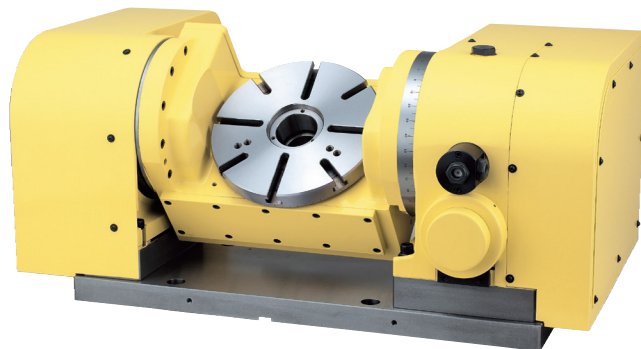

#### 5AX-201 Compact 5<sup>th</sup> Axis Table

Diameter of Table	200mm	
Clamping System	Air/Hyd	
Clamping Torque	Rotary 303/588Nm	Tilting 303/612Nm
Minimum Increment	0.001°	
Indexing Accuracy	Rotary 20sec	Tilting 60sec
Max Work Load on the Table	0-30° 60Kg	30-90° 40Kg
Driving Torque	72Nm	

#### 5AX-250 Mid Range 5<sup>th</sup> Axis Table

Diameter of Table	250mm	
Clamping System	Hyd	
Clamping Torque	Rotary 588Nm	Tilting 4900Nm
Minimum Increment	0.001°	
Indexing Accuracy	Rotary 20sec	Tilting 60sec
Max Work Load on the Table	0-30° 80Kg	30-90° 50Kg
Driving Torque	144Nm	

## FEATURES

- Monoblock high performance main spindle
- Ion-nitrided worm wheel HV1100
- Special steel/carbide worm-screw system
- Ultra-precision index accuracy available as an option
- Long life durability and performance from entirely NIKKEN manufactured components
- Bespoke work-holding available

### Large 5<sup>th</sup> Axis Range

Table Diameter -	Ø550 ~ 1200mm
Clamping Torque -	3430 ~ 19600Nm
Rotation Speed -	5.5 ~ 25min <sup>-1</sup>

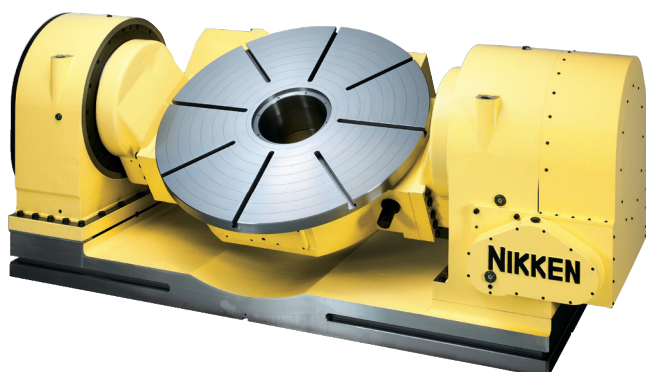

#### 5AX-1200 Large 5<sup>th</sup> Axis Table

Diameter of Table	1200mm	
Clamping System	Hyd	
Clamping Torque	Rotary 14700Nm	Tilting 19600Nm
Minimum Increment	0.001°	
Indexing Accuracy	Rotary 20sec (±5)	Tilting 60sec (±10)
Max Work Load on the Table	0-30° 2500Kg	30-90° 1500Kg
Driving Torque	3168Nm	

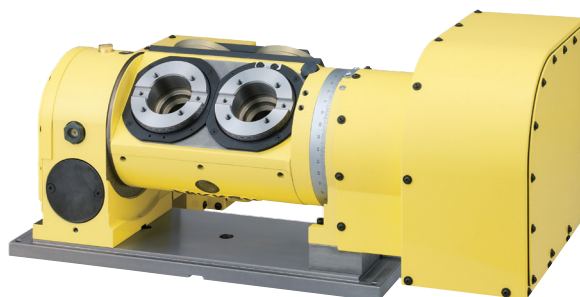

### Extended Scope

To further enhance your productivity, in addition to our standard range of rotary tables, we also provide a choice of multi-spindle options. Available for both our single axis and twin axis rotaries we have a wide range of diameters and pitches to suit any demand.

# Workholding

NIKKEN offer a complete range of work holding and fixturing accessories to suit any application to increase the productivity and scope of your platform. Whether it's a standard, off-the-shelf centring vice or fully bespoke fixturing package, our team of skilled engineers are available to create a package to suit your process for either direct supply or as part of a full turn-key solution.

Popular setups include but are not limited to; vices (with various jaw options), tombstones, pallets, trunnion setups and rail systems, all fully zero-point compatible to ensure optimal efficiency, accuracy and repeatability, in addition to being available to view at our Innovation Centre.

Both our own and our partner manufactured accessories and equipment are available on a fast turnaround.

## Trunnion

NIKKEN trunnions allow positioning and holding of single workpieces, multiple workpieces or even vices for significantly increased productivity and workflow. This solution has been developed to allow any single axis rotary table to be adapted quickly and easily, in conjunction with a suitable support, like NIKKEN's TAT solution. Our trunnions are suitable for practically every requirement, machine tool and bed length and are available in a variety of designs and lengths to meet any need.

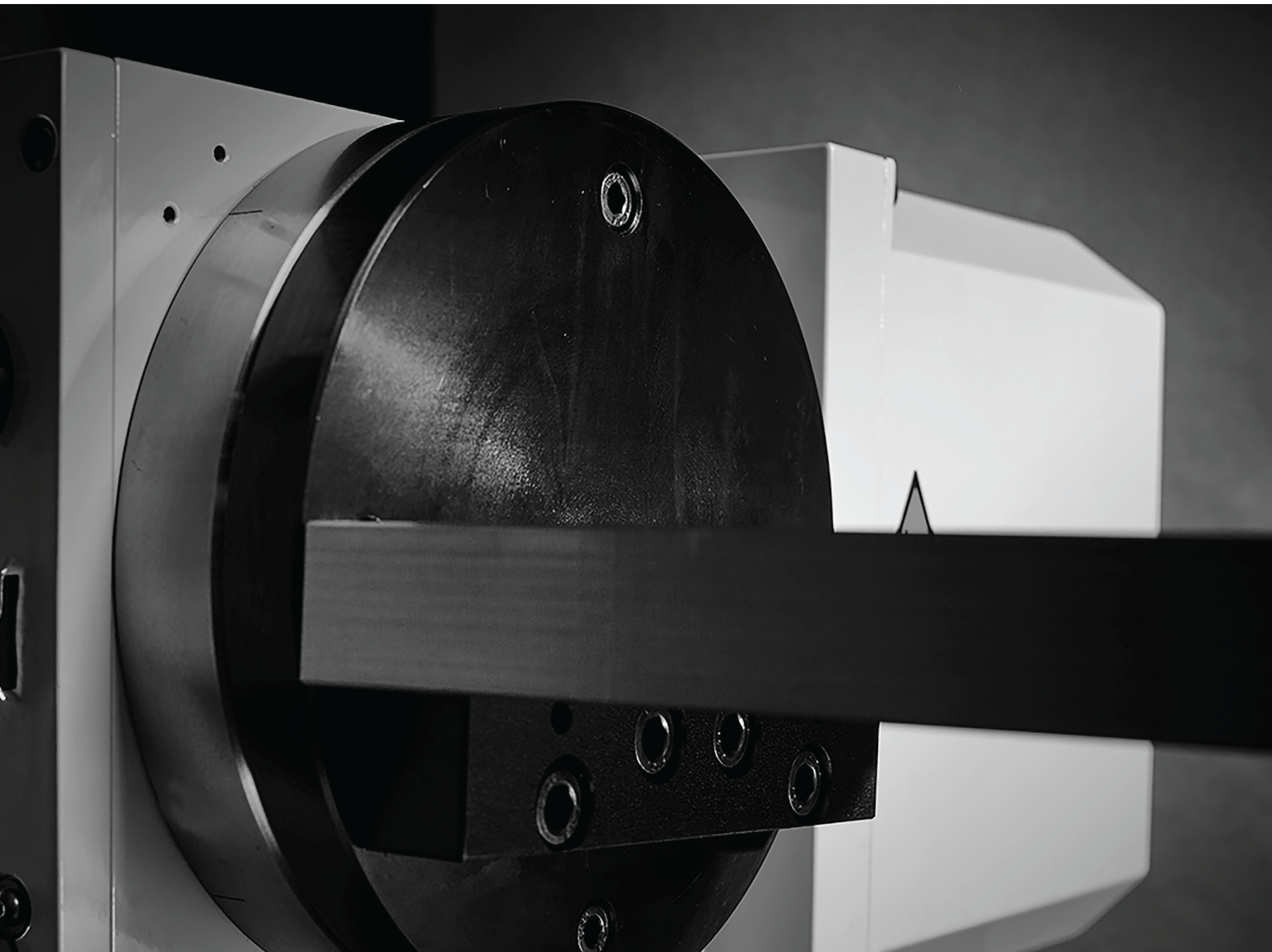

# Tool Presetters

Designed to excel tool measurement capabilities whilst increasing productivity through reduced machine downtime and absolute accuracy.



## Introducing Our New Range of E46 Presetters

Unlock the full potential of your machine tools with our E46 presetters. Accurate measurement of tools and assemblies is crucial for optimal performance in CNC and manual machines. Establishing precise offsets for tool length and diameter ensures peak efficiency.

Traditionally, tool offsets were set directly on the machine using components, fixtures, gauges, or probes. However, machine tools should be focused on cutting metal and producing parts, not measuring tool holders. Maximise production capacity by integrating one of our brand-new presetting machines into your workflow.

Our E46 presetters offer unparalleled precision and efficiency, letting your machine tools do what they do best—cutting metal and producing high-quality parts. Enhance your production facility today with our state-of-the-art E46 presetters.



### E46B, E46BA & E46BP

The E46B presetter series is engineered for precision in tool presetting, measurement, and inspection. With a durable granite base and column ensuring stability for over 30 years, this series guarantees precise and repeatable measurements. Interchangeable spindle cartridges streamline the process, reducing the number of connection interfaces and ensuring accuracy across tool holder types.

Innovative features include push-button electro-mechanical tool clamping, storage for additional spindle cartridges, and a spindle identification system for error prevention. Its intuitive operation simplifies tool measurement, with automatic positioning and multiple measurement capabilities.

The E46BA features a patented automatic spindle rotation system with pneumatic engagement of the motion transmission providing zero backlash and optimum speed control. This system allows the software to automatically measure the maximum X and Z values of a tool with a controlled 360° spindle rotation. The E46BP takes this system a step further by also providing powered axis movements which, in conjunction with the automatic spindle rotation, allow fully autonomous positioning and measurement of a preregistered tool.

- Presented on a 15.6" HD screen our innovative and newly developed OS and presetter application (standard across all E46 lines) is based on an intuitive touch, swipe and gesture system to select and deploy easily and quickly all measuring routines and functions.
- The fully interchangeable spindle cartridges provide push-button electro-mechanical tool clamping and up to six additional spindle cartridges can be stored using new optional support shelves built-in to the side of the machine structure.
- E46B cartridges have a spindle identification system (SP-ID) to prevent incorrect reference selec-



## E46C, E46CA & E46CX

With a larger 21.5" HD touch screen for increased real estate the new E46C presetter series bring multiple advantages for significantly improving any production process. While the machine is carrying out a job, the operator, or the toolroom staff, can quickly and precisely pre-set the tools for the next job.

The new AS371 optical scales allow for ultimate accuracy and precise performance. The development of this essential component is possible from over forty years of experience and know how in the field of measurement for the mechanical sector.

As with the B series presetters all spindle holders are interchangeable and are built to have an optimum level of repeatability. Without the use of adapters, the measurement becomes even more precise, as multiple coupling and the potential for build-up of error between different elements is negated.

Furthermore, the E46C presetter series is equipped with the spindle holder identification system (SP-ID). The system allows the presetting machine to identify the spindle holder and suggests the correct machine origins, every time the spindle holder is exchanged.

- E46CA and E46CX models feature a patented automatic spindle rotation system with pneumatic motion transmission, enabling zero backlash and optimal speed control. This system allows software to measure tool dimensions with 360° spindle rotation, reducing operator intervention and minimizing errors.
- The E46CX advances the powered spindle and autonomous axis positioning to full CNC capability.
- The user-friendly interface allows operators to create measurement routines, set measurement points, cutting edges, theoretical values, and tolerances on one screen, facilitating quick optimization and data export.
- E46CX offers fully automatic positioning of the vision system, precise control of the interchangeable spindle, autofocus for multiple cutting edges, and adaptive identification of geometric entities.
- The system includes data processing functions and comprehensive analysis of all measurements and results.



एनएनएल

The image shows a close-up of a silver metal component, likely part of a machine. A textured black strip is visible on the left side. The logo 'एनएनएल' (NNNL) is printed in black on the silver surface, with a red starburst graphic above the first 'न' and a yellow circle around the last 'ल'. The component is secured with screws at the top.



19.  
111.472  
312.22

X  
Z  
C

Mazak

Okuma  
genos

Mazak

Brother

Okk

Red emergency stop button

Two circular buttons on the machine tool control panel

Mazak logo

## Principles of Presetting

The measuring of individual tools and assemblies is a necessity for the effective operation of a machine tool and its tooling. All CNC Machines, and to some degree, manual machines require offset values or references for the length & diameter of each tool.

Historically, the normal practise has been to establish tool offsets and references on the machine tool using various methods - the component/fixture, some form of gauge or a probe/laser. Machine tools earn money by cutting metal and producing parts, not measuring tool holders and assemblies. Therefore, it is therefore essential, in a modern production facility, to consider a dedicated presetting machine.



### E346B

- Bench-mounted tool presetter enlarged natural granite base and column, delivering exceptional stability and a maximum linearity error of 8  $\mu\text{m}/\text{m}$  for reliable precision in demanding machine shop environments
- High thermal stability and precision construction ensure excellent accuracy, repeatability, and reproducibility for reliable tool measurement and presetting.
- Interchangeable spindle cartridge system supports a wide range of spindle interfaces (ISO,BT,CAT, HSK, Polygonal taper, etc.) while reducing adaptor connections, improving accuracy and simplifying setup.
- Integrated spindle identification (SP-ID) and taper contact confirmation verify correct spindle selection and tool positioning for increased process security.
- 15.6" vertical touch screen monitor with intuitive software enables fast tool measurement, inspection functions, and auxiliary features such as CNC machine origins and tool set creation.

### E460A

- The E460A is the entry point to our new E46 line of tool presetters, featuring the latest OS and presetter application.
- Our patented automatic spindle rotation system, with pneumatic engagement, ensures zero backlash and optimum speed control, allowing automatic measurement of maximum X and Z values with controlled 360° spindle rotation.
- The software identifies out-of-tolerance values, enabling the operator to select the edge in question for the spindle to automatically return to that point.
- Our innovative software, presented on a 15.6" HD screen, uses an intuitive touch, swipe, and gesture system for easy and quick selection and deployment of measuring routines and functions.
- Measurement data can be printed, saved, stored, or exported using the inbuilt tool management system. The E460A is also TID (Tool Identification System) ready.



## E68CX

- Our premium, highest specification presetter with autonomous axis movement and positional control. Using simple to create intelligent measurement routines assigned to a given tool reference, the machine can automatically capture and measure multi-edge tools and complicated geometric features.
- Floor-mounted, with natural granite base and column, delivering exceptional stability with a maximum linearity error of 8  $\mu\text{m}/\text{m}$  for reliable measurement accuracy.
- Automatic spindle rotation with electronic indexing and C-axis visualisation enables accurate measurement of tool edges and complex geometries during presetting and inspection.
- High-precision bi-telecentric optical measuring system with 1  $\mu\text{m}$  resolution and up to 25 $\times$  magnification, ensuring detailed inspection and accurate capture of tool geometry.
- Advanced presetting software and its functionality also support programmable workflows and high-mix precision demands; automatic geometry measurement, DXF profile import and comparison, and unlimited tool set management for efficient digital tool verification and setup.
- 21.5" vertical Full HD capacitive touch screen with intuitive graphical software enables fast tool measurement and inspection, alongside auxiliary functions such as CNC machine origins and tool set creation.

1893

# Tool Management

Streamline manufacturing processes to save time and money with Elbo Controlli NIKKEN's 360° Tool Management Solutions.



elbo controllli  NIKKEN

## TP32

TP32 is a complete 360 degree solution, developed to provide an all-round tool and stock control system for manufacturers and machine shops. TP32 meets the demands for businesses requiring a system capable of managing tool holders, cutting tools, spare parts, inserts, consumables and all associated data and information. TP32 is a program which is fundamentally dedicated to the management of the tool repository, which is woven in as a fundamental component of the productive cycle. As such, the data is inserted and managed within a system which allows all information to be accessible to all members across the manufacturing process and presented in the simplest and most straight forward and useable manner.

Through TP32, it is possible to have the stock repository under full control both as a management solution and also to the teams responsible for the composition and assembly of the individual components. In this way, everyone has all the necessary information that is required for effective production (component availability, assembly verification, etc.) including going as far as individual part and assembly administration (stock values, ordering replenishments from suppliers, etc.).



## TiD

Tool ID allows you to manage and control tool identification and geometrical data seamlessly. TiD uses a handheld scanner at the presetter to scan and read a data matrix tag (similar to a QR code) located on the tool assembly. A similar scanner is located at the machine tool connected to either a Windows PC or touchscreen console on which the TiD software is also running.

This process allows the tool data (measured or theoretical) to remain centralized within the TiD database and is transferred from the presetter directly into the tool table on the respective machine tool.

The intuitive graphical interface within TiD allows configuration of the format and the mapping for the data required for the tool identification.



## NIKKEN Innovation Centre Europe

Advanced Manufacturing Park, Brindley Way,  
Catcliffe, Rotherham, S60 5FS, UK t: +44 (0)1709  
366306 | f: +44 (0)1709 376683 e: info@nikken-world.  
com | w: www.nikken-world.com

Specifications are subject to change without notice



The Spirit of Innovation